

VESSEL DATA SHEET

Design Parameters

Pressure, Max. at Inlet	180 psi
Temperature	200 F
Corrosion Allow.	0.060"
Code Standard	ASME Sect. VIII, Div. 1
Stamped?	No

Operating Parameters

Pressure, Max.	180 psi
Temperature	200 F
Gas Flow Rate	12,000 scfh @ 10 psi
Gas Specific Gravity	0.65

Vessel Testing

Hydrotest Pressure	270 psi
Pneumatic Test Pressure	N/A
Radiograph	None
Magnetic Particle	None
Dye Penetrant	None

Filtration Performance

Filter Element P/N	2525K140
Type of Filter Media	Polyester/Paper Blend
Retention Rating	10 micron
Efficiency of Retention	99.97%
No. of Elements	1
Design Clean Press. Drop	0.33 psid
Changeout Press. Drop	12 psid

Closure Specifications

Type	Quick-Open Swing-Bolt
Gasket Type	O-Ring, P/N 023

Internal Finish

Sandblast	Light
Oil Coat	None
Glyptol Coat	None

External Finish

Sandblast	SP-10 Commercial
Primer Coat	(1) Coats Red Oxide
Intermediate Coat	None
Finish Coat	(2) Coats Grey Enamel

Schedule of Openings

Service	See Dim.	Qty.	Size	Rating	Type
Inlet	A	1	2"	150# ANSI	R or FFSSO
Outlet	B	1	2"	150# ANSI	R or FFSSO
Drain	C	1	1/2"		FNPT
Vent	D	1	1/2"		FNPT
Press. Tap	E	1	1/4"		FNPT
Press. Tap	F	1	1/4"		FNPT

Materials of Construction

Shell	SA53B	Thickness	0.258"
Bottom Head	SA234WPB		0.258"
Closure Cap	SA234WPB		0.258"
In/Out Piping	SA53B		0.154"
Flanges	SA105		ANSI 150# FF
Couplings	SA105		3000#
Closure Gasket	Buna-N Rubber		
Closure Bolts	SA449/Grade 5		1/2" dia.
Legs	N/A		
Ring Base	N/A		

Shipping Information

Total Weight	47#
--------------	-----

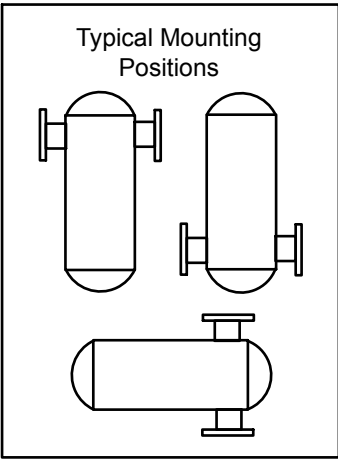
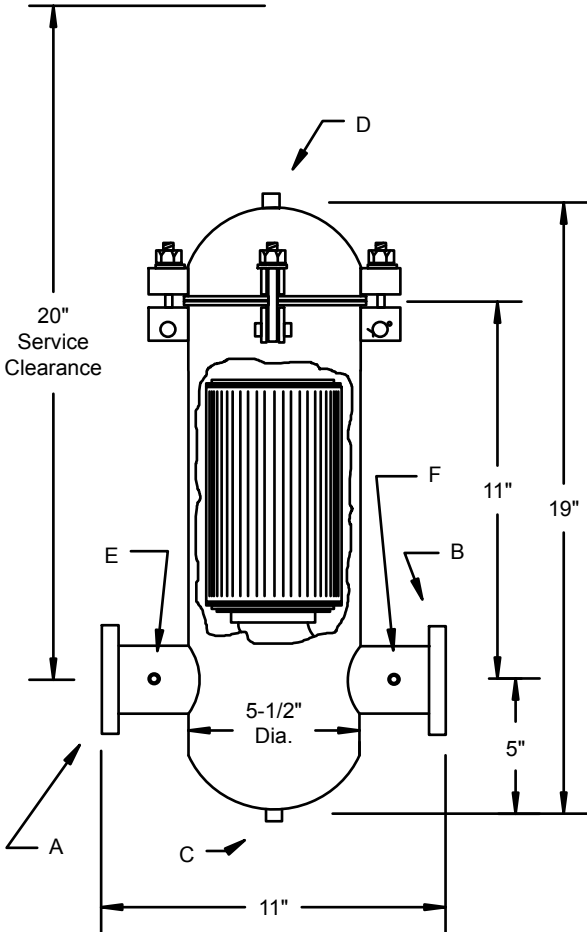

FilterFab
MANUFACTURING CORPORATION

Model F2M-180F Gas Line Filter

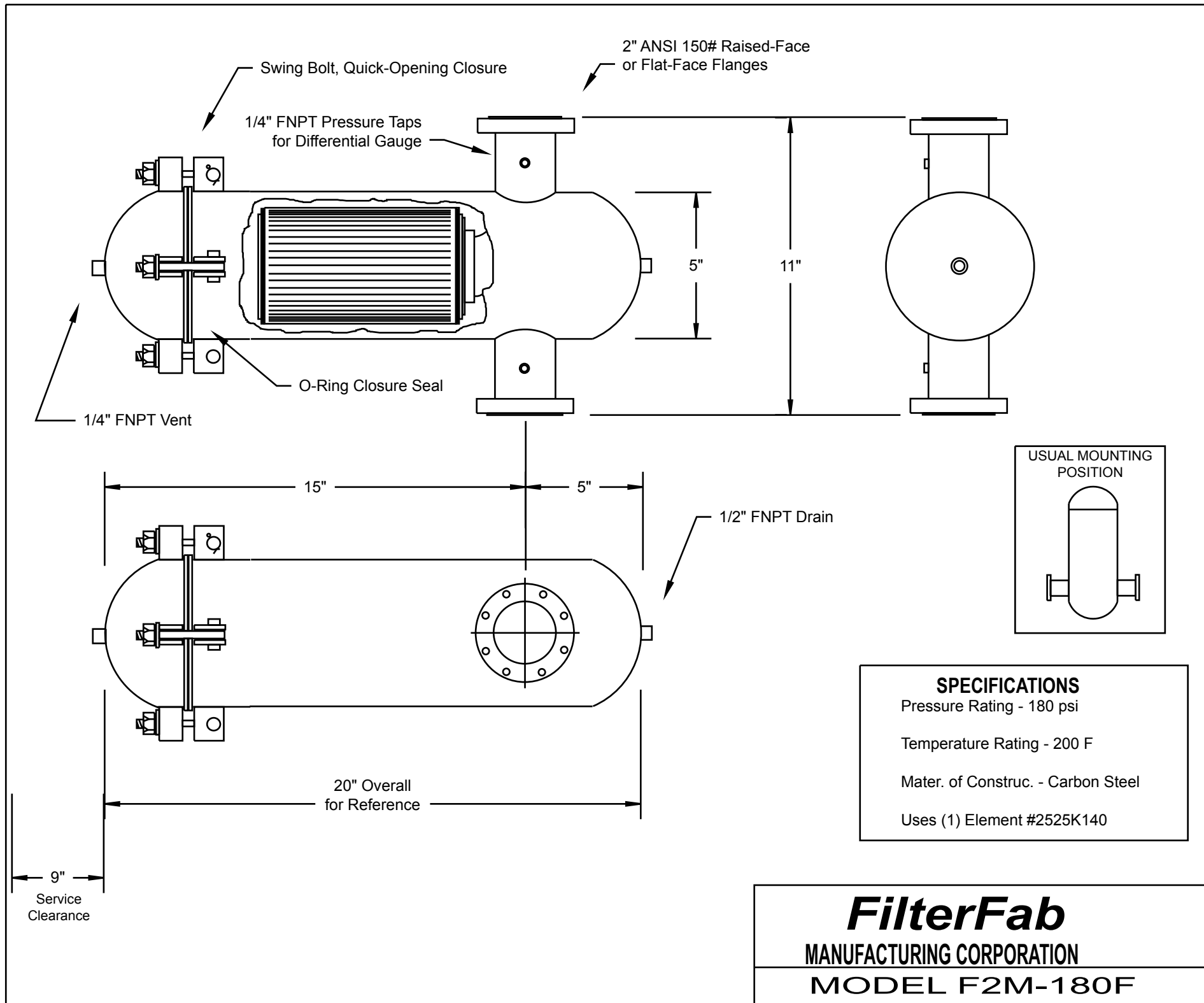

2" ANSI 150# Raised-Face or Flat-Face Flanges

Swing Bolt, Quick-Opening Closure

1/4" FNPT Pressure Taps for Differential Gauge

O-Ring Closure Seal

1/4" FNPT Vent

5"

11"

15"

5"

1/2" FNPT Drain

20" Overall for Reference

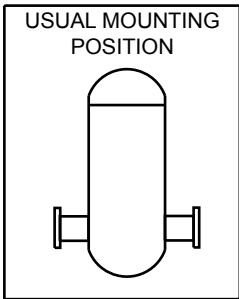

SPECIFICATIONS
 Pressure Rating - 180 psi
 Temperature Rating - 200 F
 Mater. of Construc. - Carbon Steel
 Uses (1) Element #2525K140

FilterFab
 MANUFACTURING CORPORATION
 MODEL F2M-180F

9"
 Service Clearance